

# Aluminium rolling door NovoSpeed Alu R

Industrial exterior door to 25 m<sup>2</sup>

double-walled  
aluminium strips,  
with PUR core



window sections  
(optional)

rubber bottom profile

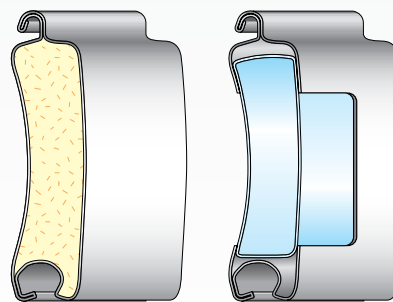

TH80 strip

THGL80 strip

## Properties

- max. surface area (WxH) = 25 m<sup>2</sup>
- max. W x H = 5000 x 5000 mm
- Class 2 wind resistant
- opens at appr. 1 m/s
- closes at appr. 0.5 m/s
- suitable for light use (approx. 25 to 50 cycles a day)
- strips of aluminium



[www.novospeedsolutions.com](http://www.novospeedsolutions.com)



The NovoSpeed Alu R is a functional and reliable door with uses in industry and public utilities. The door is suitable for large door dimensions with a choice of various operating mechanisms. As standard the NovoSpeed Alu R is supplied with insulated strips of 80 mm tall.

### Advantages

- solid frame construction
- by using a drive with frequency control the door opens smoothly and the time in the open position is reduced to a minimum
- slats can be simply replaced
- class 2 resistance to wind pressure
- low maintenance costs with simple technology and an easily accessible construction
- safe through the use of a closing edge protection system
- available in 5 standard colours or any RAL colour required
- application of transparent slats is possible

### Components and construction

The NovoSpeed Alu R is made of horizontal slats consisting of a outer and inner shell of aluminium with a CFC-free polyurethane (PUR) core. The slats are joined to allow water run-off. Lateral end pieces prevent the slats from moving in relation to each other. Elastic bands run over the door leaf in order to keep the slats scratch-free, and to reduce noise. Above the clear width the door leaf is wound up on a steel winding tube. This sits on 2 movable consoles with bearing seats.

### Strips

Double-walled aluminium with a CFC-free polyurethane (PUR) core.

- TH 80 ..... 80 mm tall and 20 mm thick
- THGL 80..... 80 mm tall and 20 mm thick

### Dimensions

- max. width (W) ..... 5000 mm
- max. height (H) ..... 5000 mm
- max. surface (WxH) ..... 25 m<sup>2</sup>
- max. windpressure ..... Class 2
- lateral space drive side ..... 300 mm
- lateral space non drive side ..... 170 mm
- head room ..... ca. 780 mm
- fitted depth ..... 850 mm

### Surface treatment

- the aluminium slats are provided as standard with a clear coating
- the steel lateral guides and consoles are galvanised
- the winding roller is finished with a primer

### Drive

The door is equipped with an electric slip-on drive with built-in drop protection and standard control box with frequency control. The control box is mounted at 1500 mm height. The drive has emergency operation using a crank.

### Controls

Other forms of operation that can be connected to the standard control box are:

- push button, pull switch or remote control with one-button operation. These all work like this: When you use it the first time the door will open, when you use it a second time the door closes
- 3-button remote control with Open-Stop-Close function
- operation via photocell

### Protection

- the electrically driven rolling door has roll-off safety that keeps the door leaf in place in the case of defects with the drive or transmission
- closing edge protection is standard

### Technical details electric drive

- power.....400V 3 ph / N + PE / 50Hz / 16A
- degree of protection .....IP65

### Structural provisions and connection (third parties)

For the electric drive with control box a wall socket (400V 3 ph / N + PE / 50Hz / 16A) must be present within 0.5 m at 1500 mm height to the left or right next to the door. A flat assembly frame and the required fitting space must be available.

### Optional extras/accessories

- slats with PVC windows
- factory coating in RAL colour 7016, 9002, 9006, 9007 or 9010 on the slats
- customer-specified RAL coating (with the exception of fluorescent and traffic colours)
- red/green indication driving in and out
- remote control