

# Swing door PTL

interior industrial door

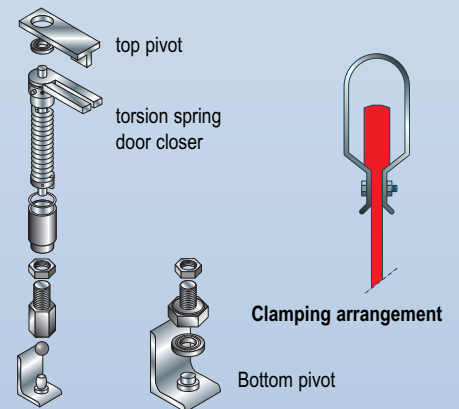
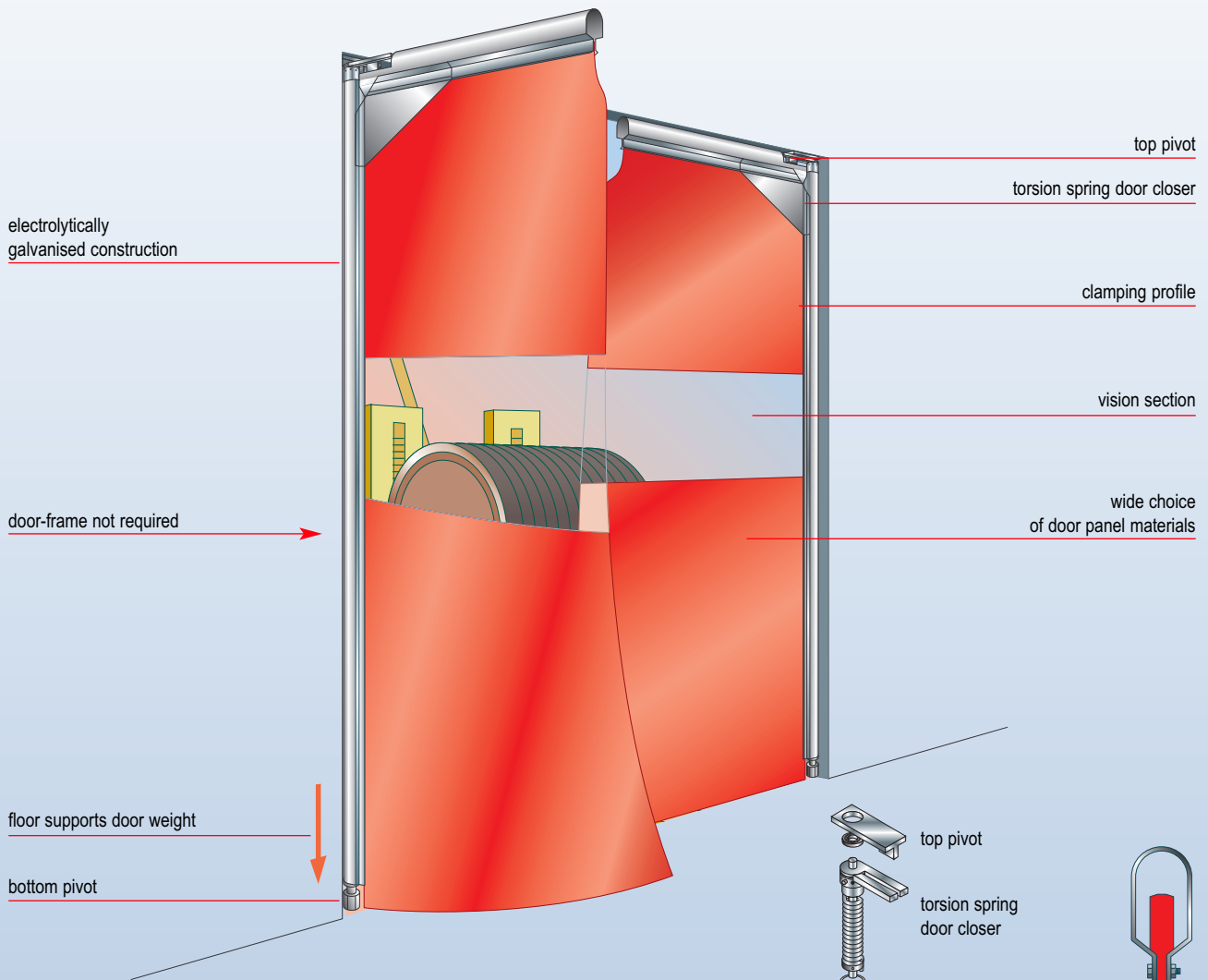

## Features

- no door-frame or steel mounting frame required
- various mounting arrangements
- wide choice of door panel materials
- electrolytically galvanised as standard
- choice of colours (RAL)
- also available in stainless steel (304).

### Many extras, such as:

- raised bottom pivot
- vision panel, windows or portholes.

**novoferm**<sup>®</sup>

*Novoferm's PTL climate control doors create a functional separation between two areas without impeding the passage of personnel and materials handling equipment, as the door can simply be pushed open. These doors are used in industrial buildings and public utilities.*

## Components and construction

Novoferm PTL climate control doors are available as single or double leaf designs. The doors consist of a frame made of steel clamping profiles (gallows construction). There is a choice of rubber or flexible plastic door leaf materials, in a variety of thicknesses, grades and colours and with various vision options. The top pivots are fitted with ball bearings, the bottom pivots use a ball collar thrust bearing. The doors close automatically under the influence of a torsion spring door closer, which can be adjusted from the outside and is mounted in the top part of the vertical tube where it is protected against dust and from the effects of collisions.

## Mounting arrangements

- 1) 2 x 90° (standard)
- 2) 1 x 90° and 1 x 180°

## Materials

### construction

- pressed steel plate, electrolytically galvanised (or stainless steel 304).

### door leaf

- transparent plastic sheet (5 and 7 mm) (1)
- reinforced transparent plastic sheet (7 mm thick) (1)
- wear-resistant black rubber, 6 and 8 mm thick, with inlays
- ivory, black, grey, red or brown plastic sheet, 7 mm thick.

### windows

- vision panel at a height between 1250 and 1750 mm from the floor
- high-frequency welded windows
- portholes fitted with safety glass.

## Finish

The steel parts of the door are electrolytically galvanised.

## Afmetingen

- max. width ..... 3000 mm
- max. height ..... 3000 mm
- max. surface area ..... 8 m<sup>2</sup>

## Operators

The forklift truck pushes the door open, following which the door automatically closes under the influence of the integral door closer.

## Structural requirements

Installation of Novoferm's PTL climate control door does not require the presence of a door-frame around the periphery of the opening. The entire weight of the door bears on the floor. A steel or concrete lintel is sufficient.

## Auxiliary components/ options/ accessories

- door stop
- mounting plate with welded pivots
- three-sided door-frame fitted with pivots

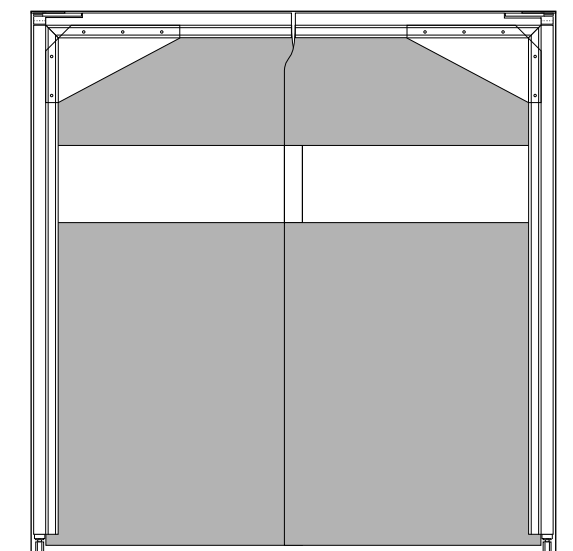

Front view

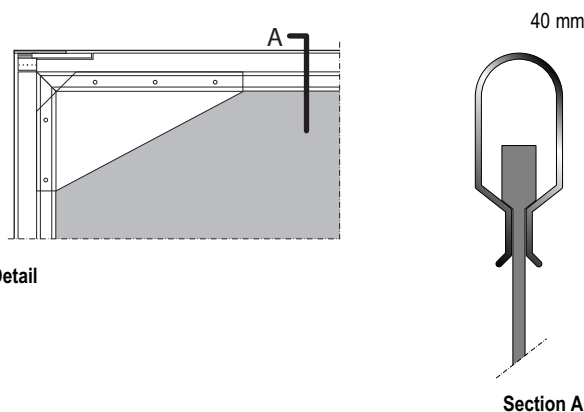

Detail

Section A

Arrangement 1  
2 x 90°  
in the clear opening

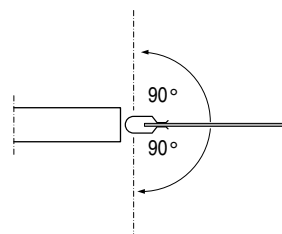

Arrangement 2  
1 x 90° and 1 x 180°  
in front of the  
clear opening

